

DISPENSA

Plnovýsuv s nízkou montážní výškou

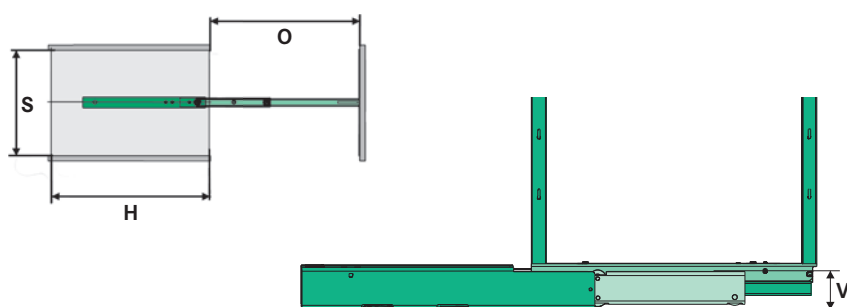

Světlá výška skříně:

a) 900 – 1 300 mm

b) 1 200 – 1 600 mm

c) 1 800 – 2 200 mm

d) 1 900 – 2 300 mm

Výška rámu = světlá výška skříně – 55 mm

V = výška spodního vedení: 35 mm

S = světlá šířka skříně: ≥ 212 mmH = světlá hloubka skříně: ≥ 500 mm

O = plné otevření: 470 mm

Nosnost: ≤ 100 kg

DISPENSA

Částečný výsuv

DISPENSA Výsuv pro 150 mm

Výška rámu = světlá výška skříně – 55 mm

V = výška spodního vedení: 43 mm

S = světlá šířka skříně: ≥ 112 mmH = světlá hloubka skříně: ≥ 500 mm

O = plné otevření: 370 mm

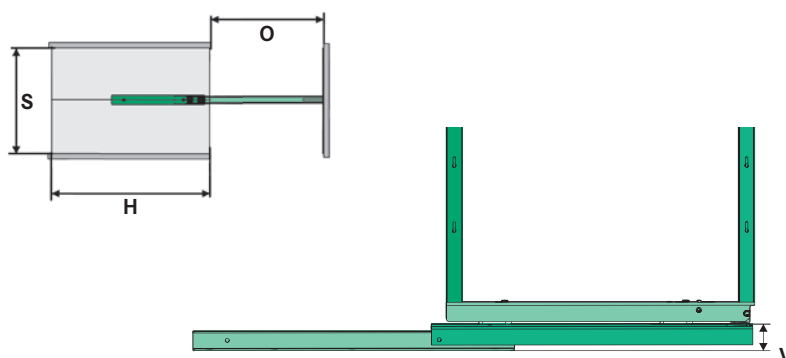
Nosnost: ≤ 100 kg

Seřízení se provede dvěma šrouby na rámu nahoře a dvěma dole – seřízení je velmi jednoduché. Potřebné nářadí: křížový šroubovák. Okamžitá vizuální kontrola během práce zaručuje rychlost a preciznost seřízení skříně.

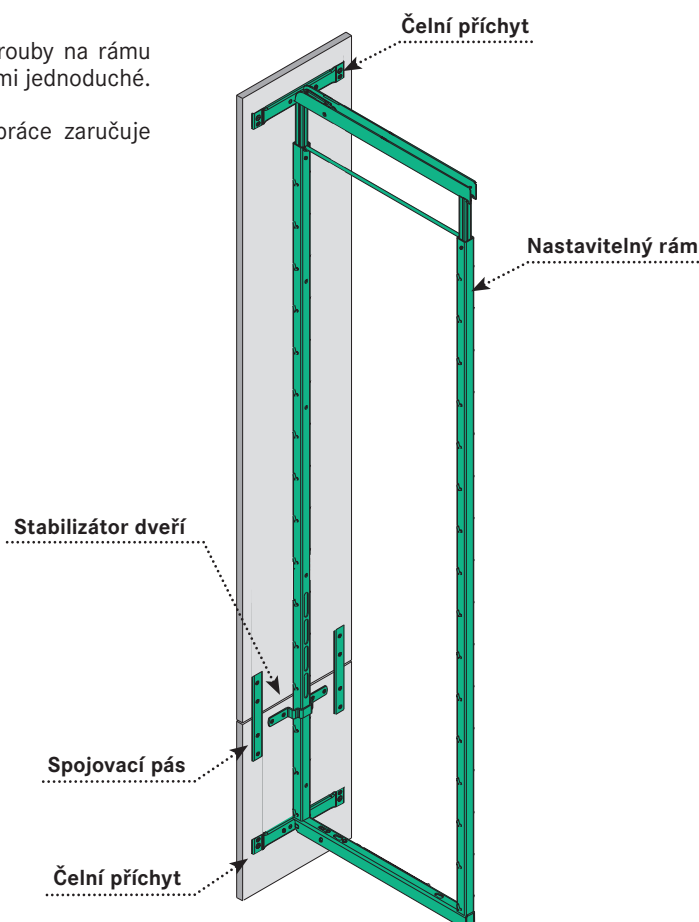
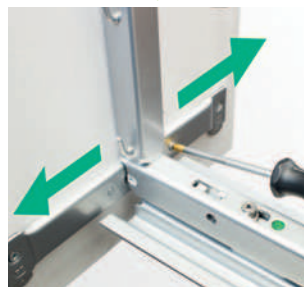

CONVOY Premio

Na dveře doporučujeme vynášecí závěsy.

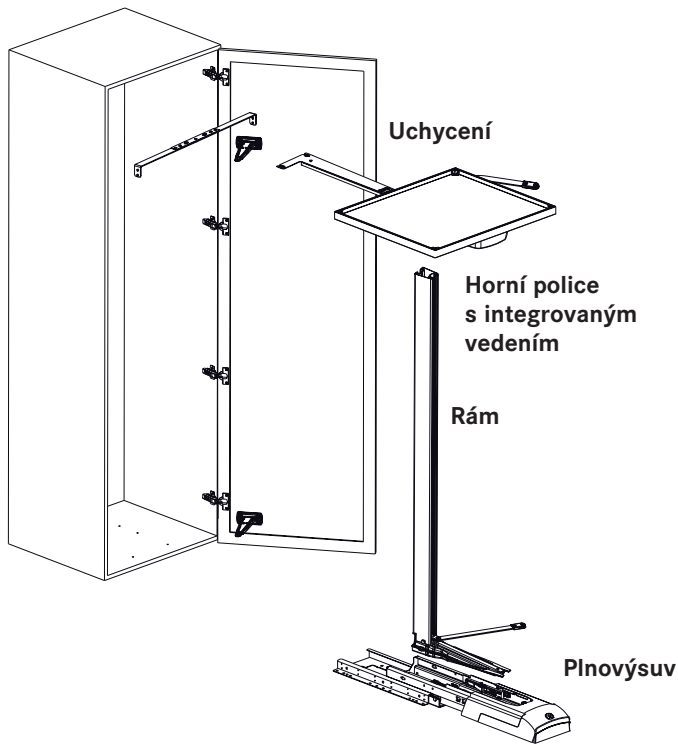

Horní police

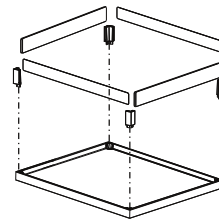

Skleněné bočnice

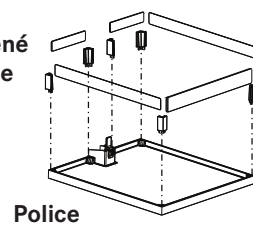

Police

TANDEM side

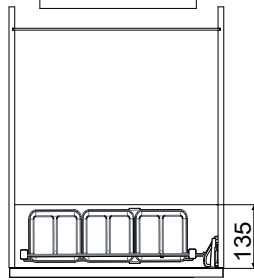
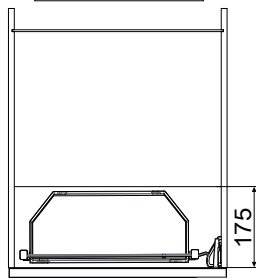
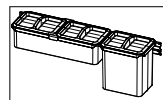
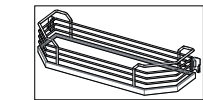
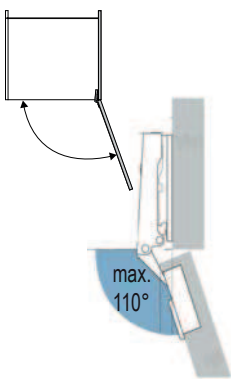

+



=

max
25 kg

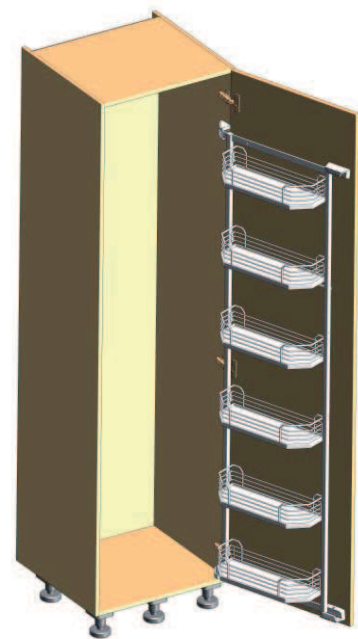
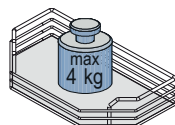

TANDEM

Šířka skříně	450 mm	500 mm	600 mm
S = světlá šířka skříně:	≥ 412 mm	≥ 462 mm	≥ 562 mm
H = světlá hloubka skříně:	≥ 500 mm	≥ 500 mm	≥ 500 mm
V = světlá výška skříně:			3 koše: od 800 mm
	4 koše: od 1 100 mm	4 koše: od 1 100 mm	4 koše: od 1 100 mm
	6 košů: od 1 700 mm	6 košů: od 1 700 mm	6 košů: od 1 700 mm
O = úhel otevření:	110°	110°	110°
max. zatížení při 6 koších:	Výsuv: 50 kg	Výsuv: 50 kg	Výsuv: 60 kg
	Dveře: 20 kg	Dveře: 20 kg	Dveře: 25 kg

Zavřený

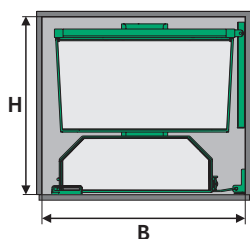

Otevřený

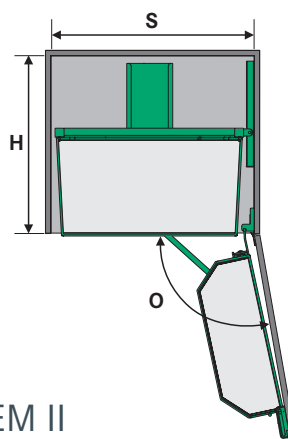

TANDEM I

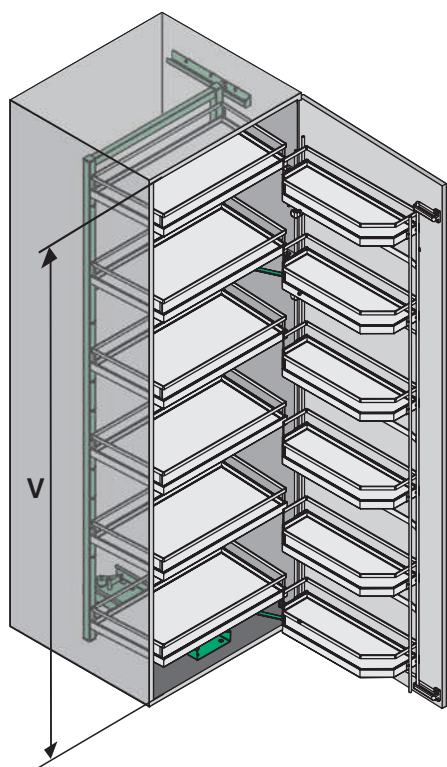

TANDEM II

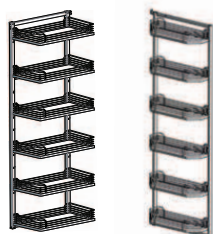
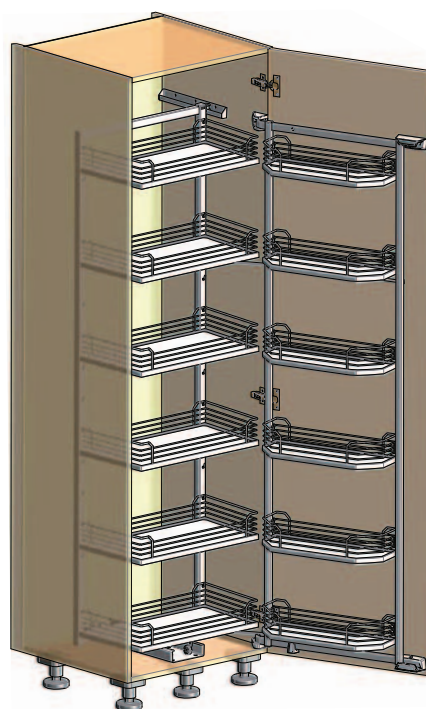

+  = max 85 kg

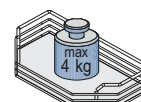
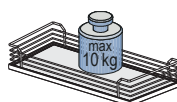

eTouch+

A DISPENSA CONVOY Centro

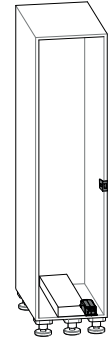
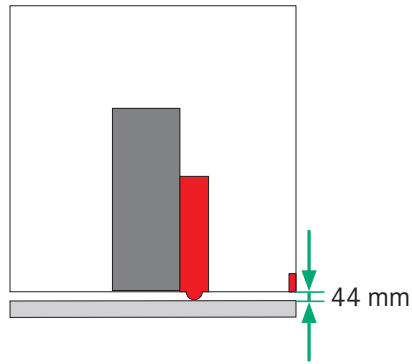
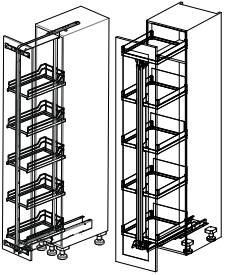

B CONVOY Premio

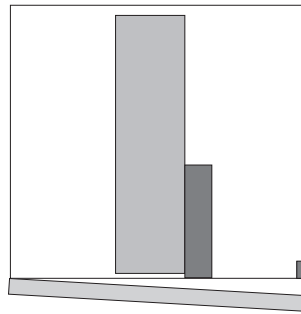
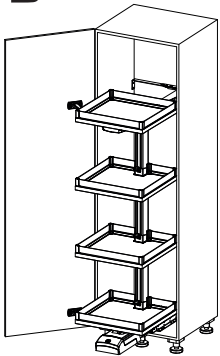

(L)

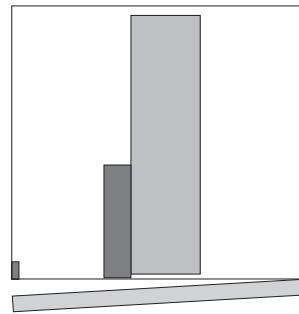

(P)

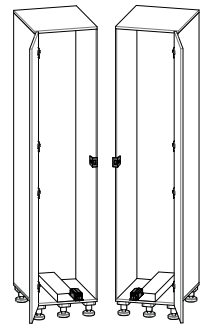

C TANDEM side

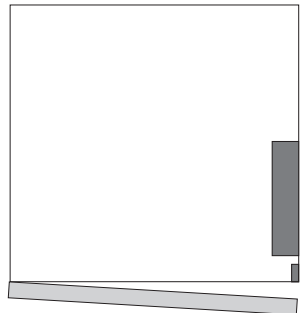
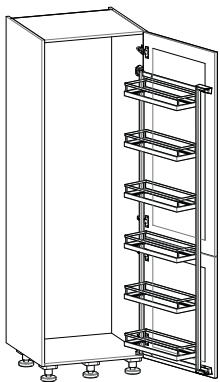

(L)

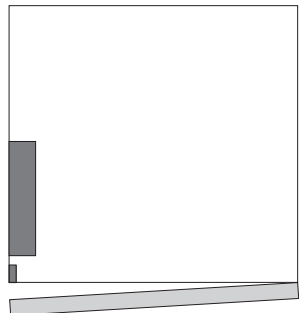

(P)

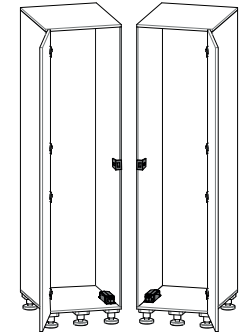

D TANDEM II

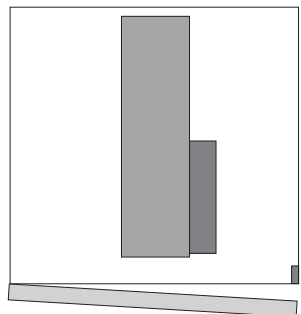
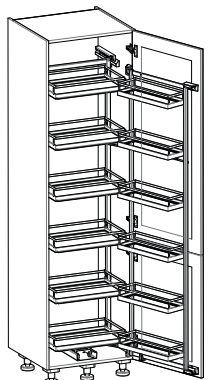

(L)

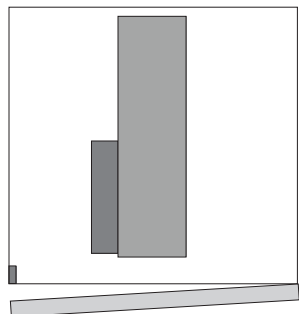

(P)

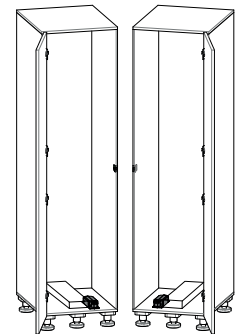

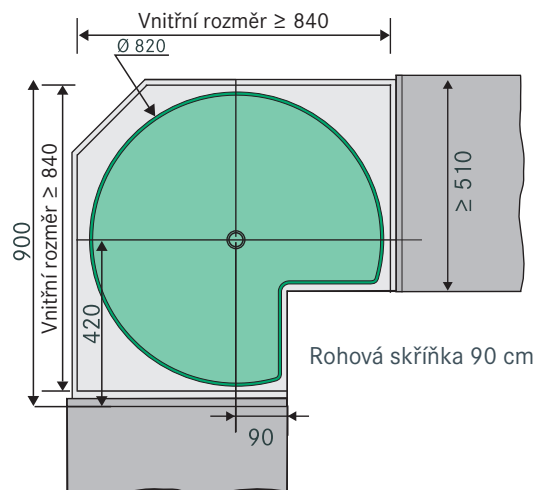
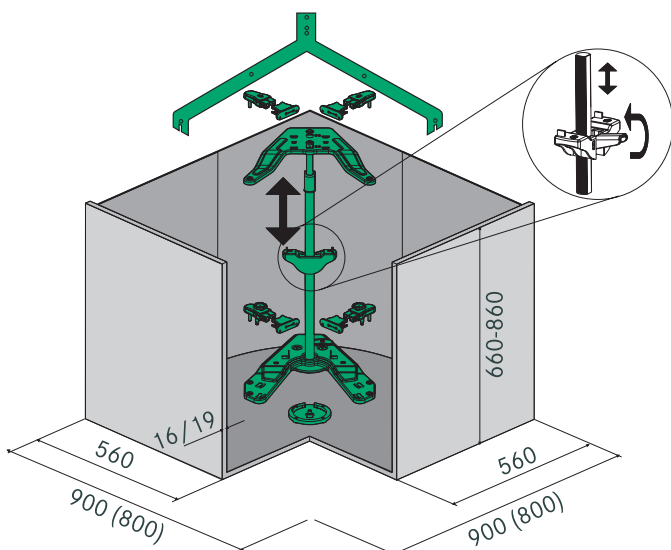
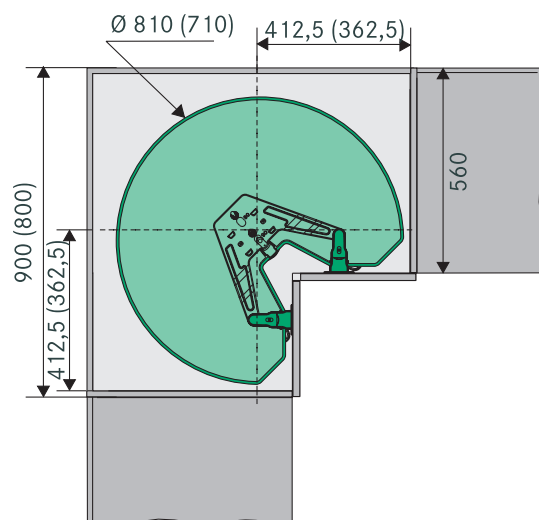
¾ KARUSEL**REVO 90****VÝSUV 15-3D**

Dvě police

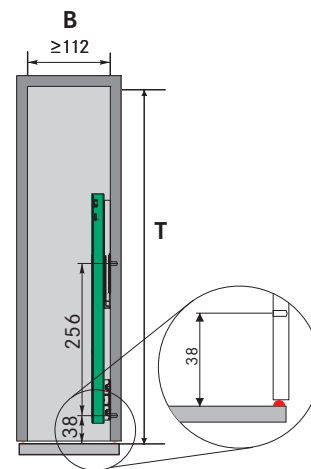
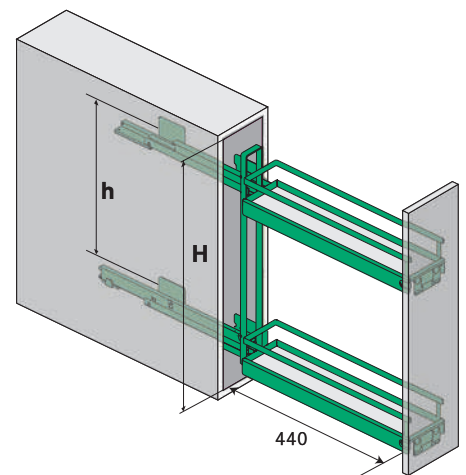

B = světlá šířka:	≥ 112 mm
T = světlá hloubka:	≥ 481 mm
H = světlá výška:	≥ 542 mm
h = vzdálenost vrtání:	380 mm

VÝSUV 15-3D

Na utěrky

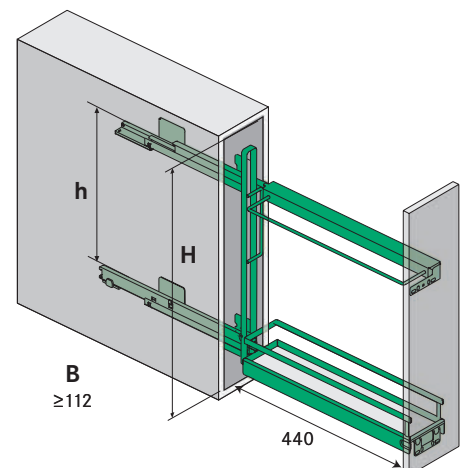

LeMans II

Šířka dvířek:

mm	400	450	500	600
A	≥764	≥800	≥910	≥960
B	≥500	≥500	≥500	≥500
C	361-368	411-418	461-468	561-568
D	16-19	16-19	16-19	16-19
E	≥60	≥60	≥60	≥60
F	≤400	≤450	≤500	≤600
G	≤65	≤65	≤65	≤65
H	600-900	600-900	600-900	600-900
J	≤25	≤25	≤25	≤25
K	≤70	≤70	≤70	≤70

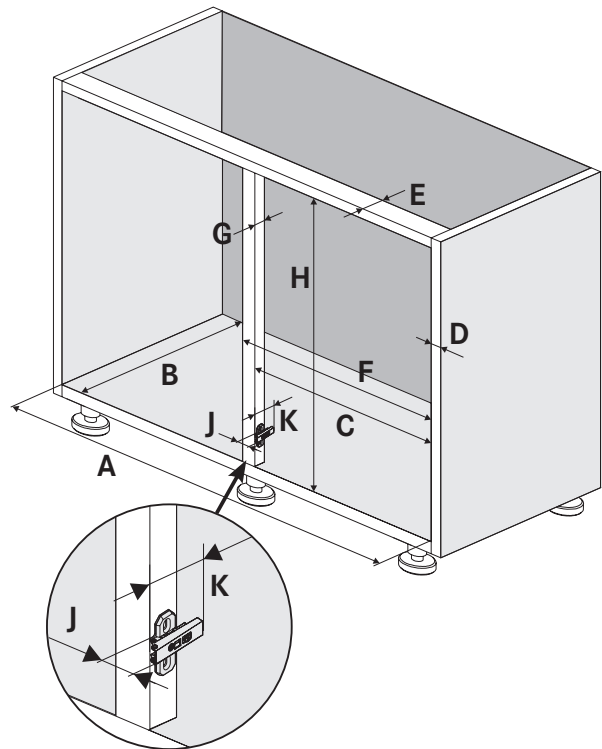

Šířka dvířek: 400 mm

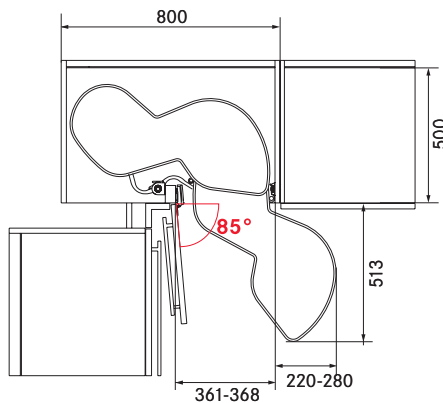

Šířka dvířek: 450 mm

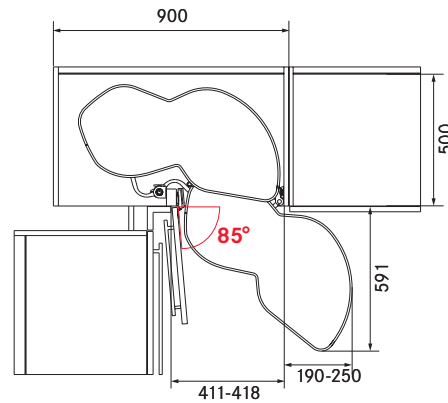

Šířka dvířek: 500 mm

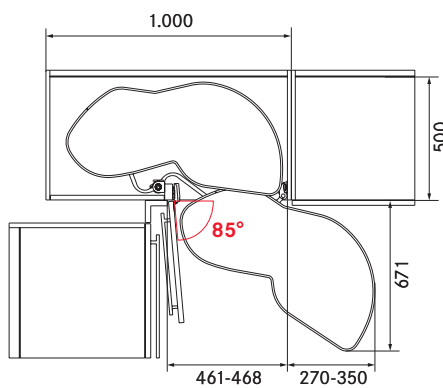

Šířka dvířek: 600 mm

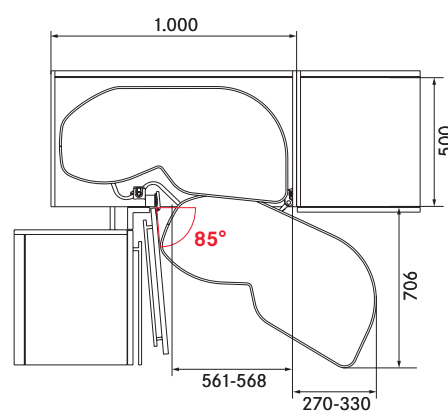

COMFORT II

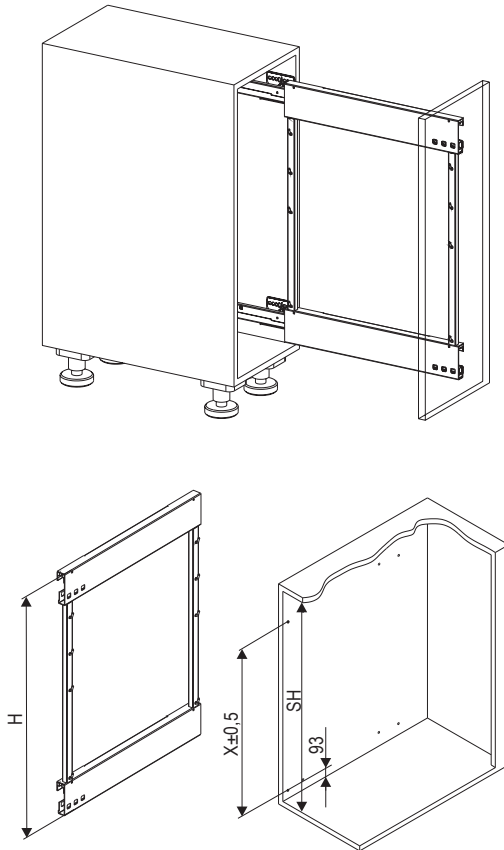

H	X	SH
630	544	min. 654
662	576	min. 686

$L = \text{Š (šířka koše)} + 33 \text{ mm}$

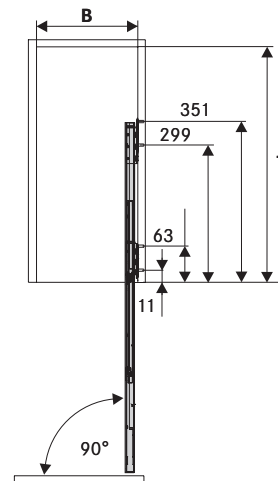
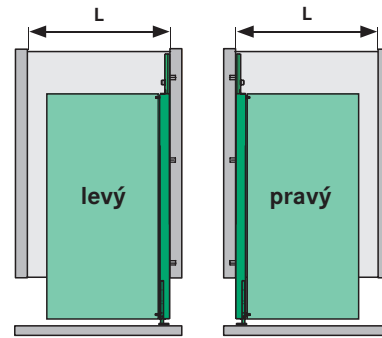

T = světlá hloubka:	≥ 496 mm
B = světlá šířka:	šířka koše + 33 mm

MagicCorner

Rohová skříňka

B = světlá šířka skříně:	860-971 mm
H = světlá hloubka skříně:	≥ 485 mm
V = světlá výška skříně:	≥ 525 mm
šířka dvířek:	≥ 450 mm
Nosnost Přední výsuv:	14 kg
Zadní výsuv:	18 kg

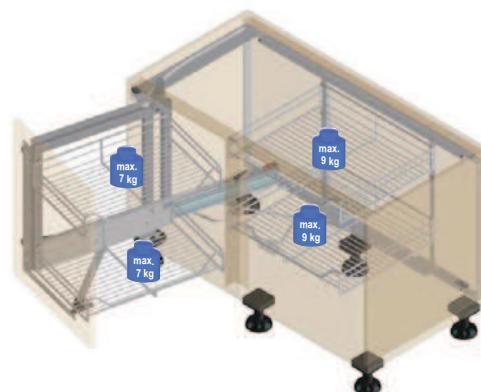
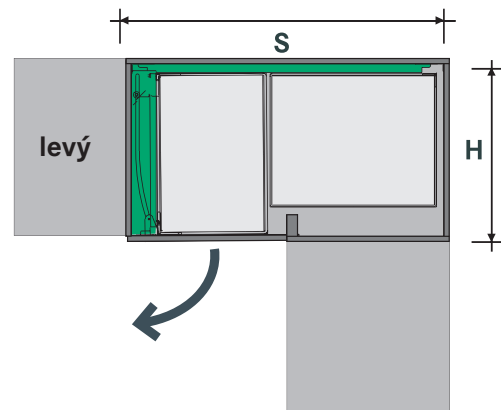
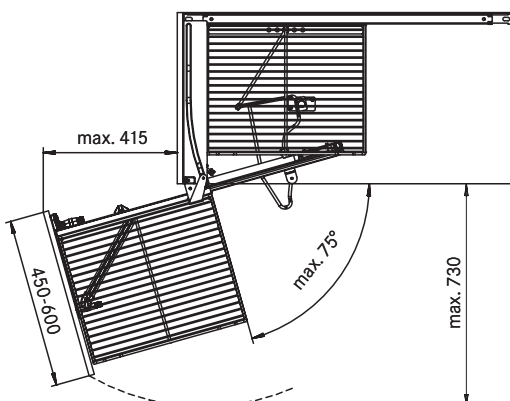

DISPENSA junior III

LB = světlá šířka:	≥ šířka korpusu B -40 mm
LT = světlá hloubka:	≥ 480 mm
LH = světlá výška:	≥ 615 mm

B
300 mm
400 mm
450 mm
500 mm
600 mm

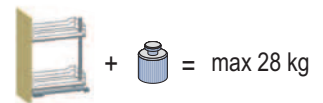
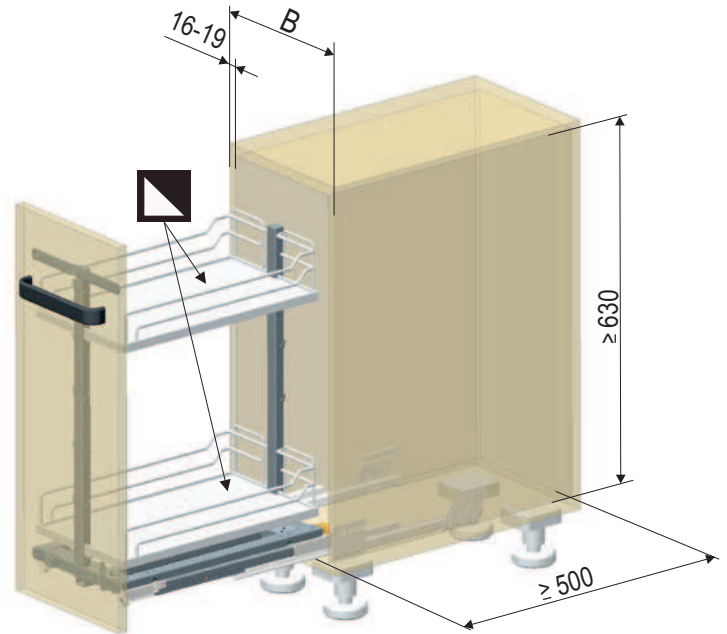
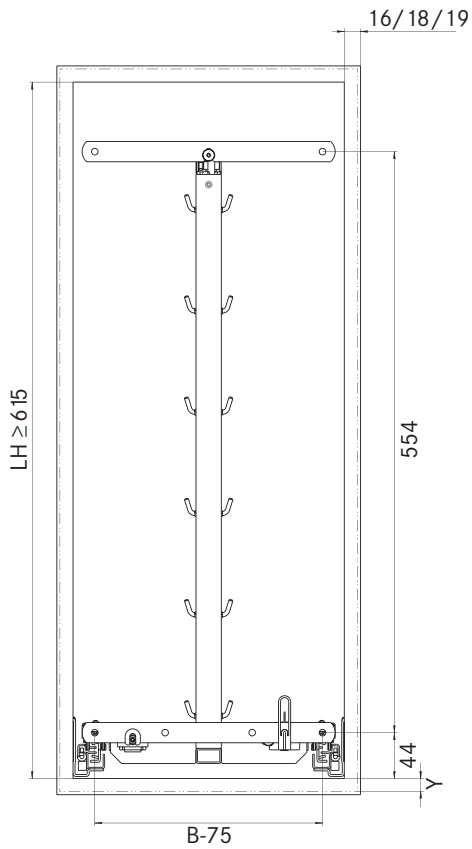

DISPENSA junior slim

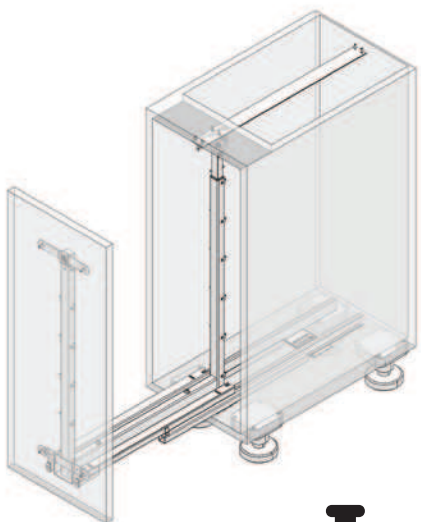

FH	h
551 mm	640-728 mm

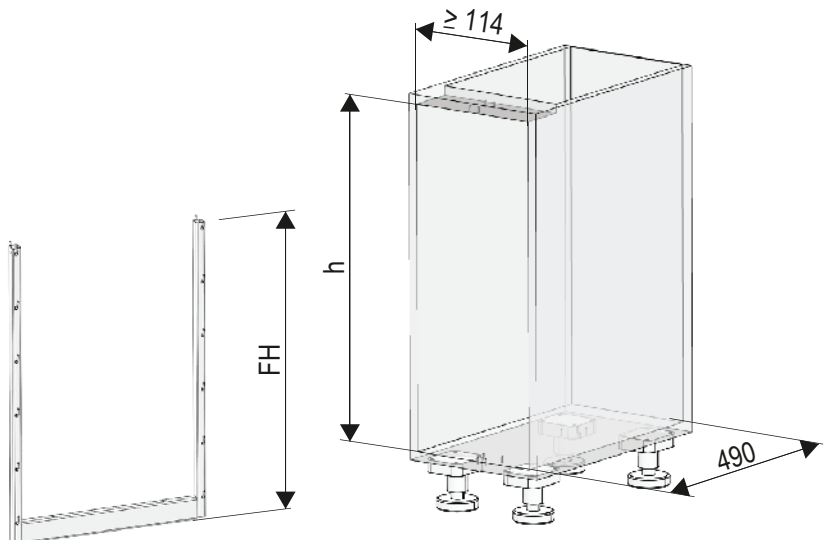
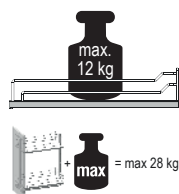

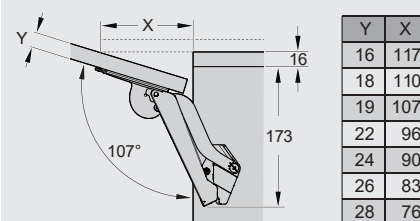

TABULKA PRO SPRÁVNÝ VÝBĚR FREEspace a FREEspace PTO

	Typ B	Typ C	Typ D	Typ E	Typ F
bílá	272234.9966	272235.9966	272236.9966	272237.9966	272238.9966
šedá	272234.7035	272235.7035	272236.7035	272237.7035	272238.7035
antracit	272234.7500	272235.7500	272236.7500	272237.7500	272238.7500
černá	272257.9005	272258.9005	272259.9005	272260.9005	272261.9005
výška čela mm	hmotnost čela* kg	hmotnost čela* kg	hmotnost čela* kg	hmotnost čela* kg	hmotnost čela* kg
225	2,3 - 4,3	3,8 - 7,1	6,4 - 9,3	9,2 - 13,4	13,4 - 19,1
250	1,9 - 3,9	3,4 - 6,4	5,8 - 9,1	8,3 - 12,6	12,1 - 17,2
275	1,9 - 3,5	3,1 - 5,8	5,3 - 8,2	7,5 - 12,0	11,0 - 15,6
300	1,7 - 3,2	2,8 - 5,3	4,8 - 7,5	6,9 - 11,0	10,1 - 14,3
325	1,6 - 3,0	2,6 - 4,9	4,4 - 7,0	6,4 - 10,2	9,3 - 13,2
350	1,5 - 2,8	2,4 - 4,6	4,1 - 6,5	5,9 - 9,5	8,6 - 12,3
375	1,3 - 2,6	2,2 - 4,3	3,8 - 6,0	5,5 - 8,8	8,1 - 11,4
400	1,2 - 2,4	2,1 - 4,0	3,6 - 5,6	5,2 - 8,3	7,6 - 10,7
425	1,1 - 2,3	2,0 - 3,8	3,4 - 5,3	4,9 - 7,8	7,1 - 10,1
450	1,0 - 2,1	1,9 - 3,5	3,2 - 5,0	4,6 - 7,3	6,7 - 9,5
475	1,0 - 2,0	1,8 - 3,4	3,0 - 4,7	4,3 - 7,0	6,4 - 9,0
500	0,9 - 1,9	1,7 - 3,2	2,9 - 4,5	4,1 - 6,6	6,0 - 8,6
525	0,9 - 1,8	1,6 - 3,0	2,7 - 4,3	3,9 - 6,3	5,7 - 8,2
550	0,8 - 1,7	1,5 - 2,9	2,6 - 4,1	3,7 - 6,0	5,5 - 7,8
575	0,8 - 1,7	1,4 - 2,8	2,5 - 3,9	3,6 - 5,7	5,2 - 7,4
600	0,8 - 1,6	1,4 - 2,7	2,4 - 3,7	3,4 - 5,5	5,0 - 7,1
625	0,7 - 1,5	1,3 - 2,5	2,3 - 3,6	3,3 - 5,3	4,8 - 6,8
650	0,7 - 1,5	1,3 - 2,4	2,2 - 3,5	3,2 - 5,1	4,6 - 6,6

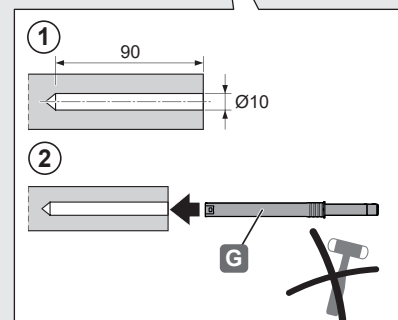
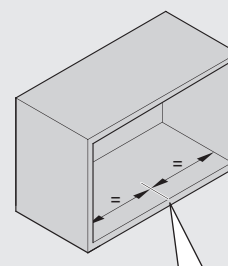
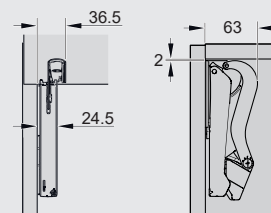

Y	X
16	117
18	110
19	107
22	96
24	90
26	83
28	76



	Typ B PTO-PUSH	Typ C PTO-PUSH	Typ D PTO-PUSH	Typ E PTO-PUSH
bílá	272243.9966	272244.9966	272245.9966	272246.9966
šedá	272243.7035	272244.7035	272245.7035	272246.7035
antracit	272243.7500	272244.7500	272245.7500	272246.7500
černá	272266.9005	272267.9005	272268.9005	272269.9005
výška čela mm	hmotnost čela* kg	hmotnost čela* kg	hmotnost čela* kg	hmotnost čela* kg
225	2,3 - 4,3	3,8 - 7,1	6,4 - 9,3	9,2 - 13,4
250	1,9 - 3,9	3,4 - 6,4	5,8 - 9,1	8,3 - 12,6
275	1,9 - 3,5	3,1 - 5,8	5,3 - 8,2	7,5 - 12,0
300	1,7 - 3,2	2,8 - 5,3	4,8 - 7,5	6,9 - 11,0
325	1,6 - 3,0	2,6 - 4,9	4,4 - 7,0	6,4 - 10,2
350	1,5 - 2,8	2,4 - 4,6	4,1 - 6,5	5,9 - 9,5
375	1,3 - 2,6	2,2 - 4,3	3,8 - 6,0	5,5 - 8,8
400	1,2 - 2,4	2,1 - 4,0	3,6 - 5,6	5,2 - 8,3
425	1,1 - 2,3	2,0 - 3,8	3,4 - 5,3	4,9 - 7,8
450	1,0 - 2,1	1,9 - 3,5	3,2 - 5,0	4,6 - 7,3
475	1,0 - 2,0	1,8 - 3,4	3,0 - 4,7	4,3 - 7,0
500	0,9 - 1,9	1,7 - 3,2	2,9 - 4,5	4,1 - 6,6
525	0,9 - 1,8	1,6 - 3,0	2,7 - 4,3	3,9 - 6,3
550	0,8 - 1,7	1,5 - 2,9	2,6 - 4,1	3,7 - 6,0
575	0,8 - 1,7	1,4 - 2,8	2,5 - 3,9	3,6 - 5,7
600	0,8 - 1,6	1,4 - 2,7	2,4 - 3,7	3,4 - 5,5
625	0,7 - 1,5	1,3 - 2,5	2,3 - 3,6	3,3 - 5,3
650	0,7 - 1,5	1,3 - 2,4	2,2 - 3,5	3,2 - 5,1

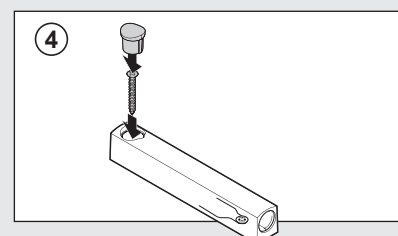
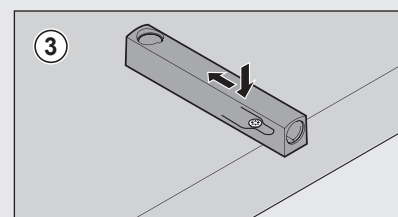
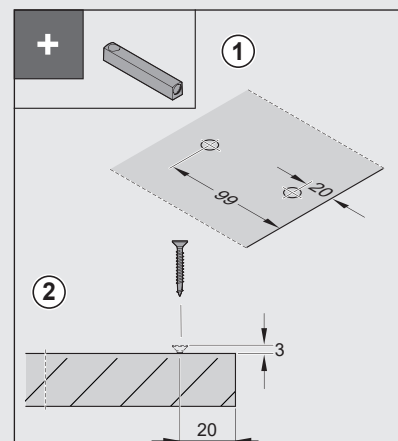

*hmotnost čela včetně 2 kusů úchytek

TABULKA PRO SPRÁVNÝ VÝBĚR FREEflap **mini**

	Typ A	Typ B	Typ C
bílá	271661.7035	271662.7035	271663.7035
šedá	271661.9966	271662.9966	271663.9966
výška korpusu mm	hmotnost čela* kg	hmotnost čela* kg	hmotnost čela* kg
≥200	1,7 - 4,6	3,7 - 7,9	6,8 - 14,7
≤225	1,5 - 4,1	3,1 - 7,1	6,0 - 13,1
≤250	1,3 - 3,8	2,9 - 6,4	5,4 - 11,8
≤275	1,2 - 3,3	2,5 - 5,7	4,8 - 10,6
≤300	1,1 - 3,1	2,4 - 5,1	4,4 - 9,6
≤325	1,0 - 2,8	2,1 - 4,6	4,0 - 8,8
≤350	0,9 - 2,6	2,0 - 4,2	3,7 - 8,1
≤375	0,9 - 2,3	1,9 - 3,8	3,5 - 7,5
≤400	0,8 - 2,1	1,7 - 3,6	3,2 - 7,0
≤425	0,7 - 1,9	1,5 - 3,4	2,9 - 6,5
≤450	0,6 - 1,7	1,4 - 3,2	2,7 - 6,1

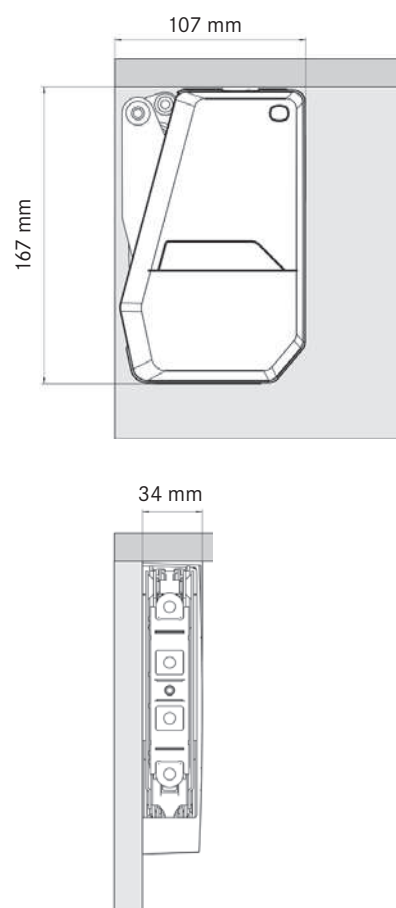
 TABULKA PRO SPRÁVNÝ VÝBĚR FREEflap **forte**

	Typ D	Typ E	Typ F	Typ G
bílá	271664.7035	271665.7035	271666.7035	271667.7035
šedá	271664.9966	271665.9966	271666.9966	271667.9966
výška korpusu mm	hmotnost čela* kg	hmotnost čela* kg	hmotnost čela* kg	hmotnost čela* kg
≤350	5,2 - 11,0	6,7 - 14,3	10,1 - 21,4	13,5 - 27,3
≤375	4,9 - 10,2	6,3 - 13,1	9,4 - 19,8	12,5 - 25,2
≤400	4,7 - 9,6	5,9 - 12,4	8,9 - 18,6	11,8 - 23,3
≤425	4,4 - 9,0	5,6 - 11,6	8,3 - 17,4	11,0 - 21,8
≤450	4,1 - 8,4	5,2 - 10,9	7,8 - 16,3	10,4 - 20,5
≤475	3,9 - 8,0	4,9 - 10,3	7,4 - 15,4	9,8 - 19,3
≤500	3,7 - 7,5	4,7 - 9,7	7,0 - 14,6	9,2 - 18,3
≤525	3,5 - 7,1	4,4 - 9,2	6,6 - 13,9	8,8 - 17,3
≤550	3,3 - 6,8	4,2 - 8,8	6,3 - 13,2	8,3 - 16,5
≤575	3,2 - 6,5	4,0 - 8,4	6,0 - 12,5	8,0 - 15,6
≤600	3,0 - 6,2	3,8 - 8,0	5,7 - 12,0	7,6 - 15,0
≤625	2,8 - 5,9	3,6 - 7,6	5,4 - 11,5	7,2 - 14,4
≤650	2,6 - 5,6	3,4 - 7,3	5,3 - 11,0	6,9 - 14,0

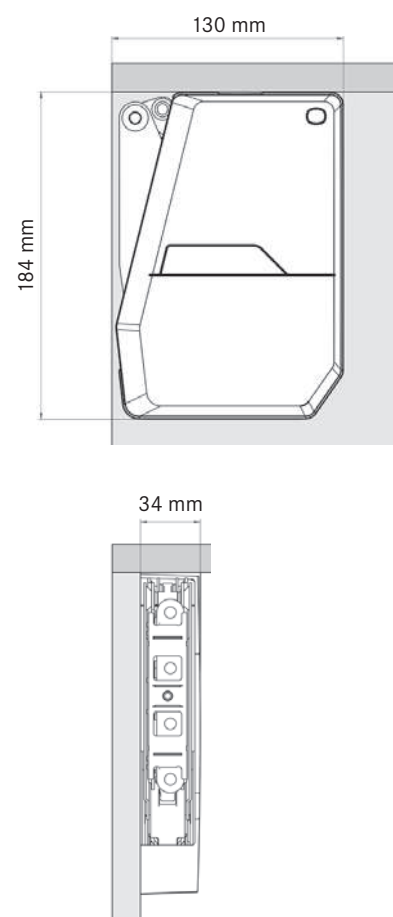

*hmotnost čela včetně úchytky

YouK

Rozměry v mm

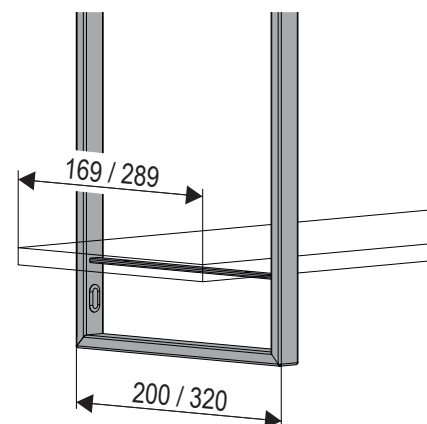
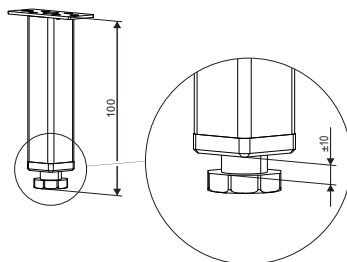
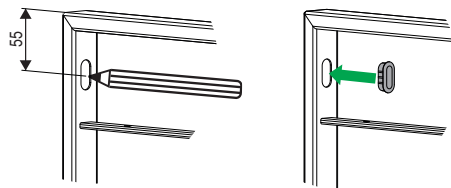

iMOVE

Rozměry v mm

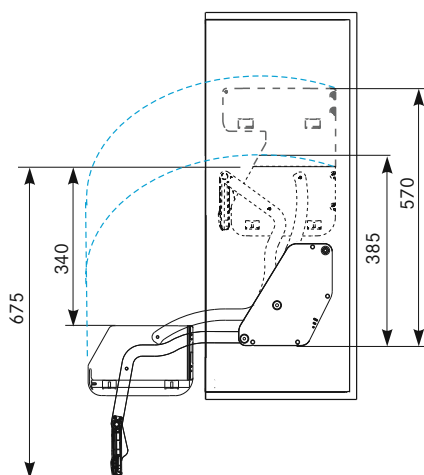

Vzorec pro určení polohy

$$Y \geq 295 \Leftrightarrow X = 82$$

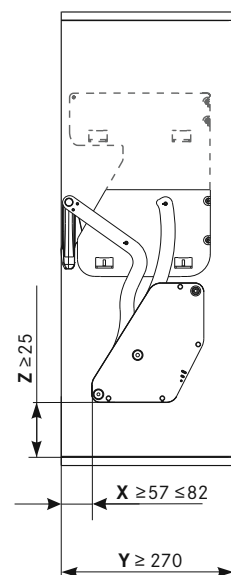

TurnMotion II

Montážní schéma
jednopatrový

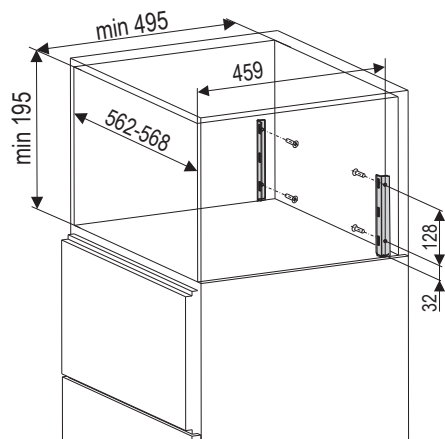

Montážní schéma
dvoupatrový

